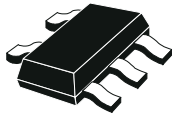


## 300 mA, 28 V low-dropout voltage regulator, with 5 $\mu$ A quiescent current



SOT23-5L

### Features

- Wide input voltage range : 2.5 V to 28 V
- Ultra-low quiescent current: typ. 5  $\mu$ A at no-load, 10  $\mu$ A max. across full temperature range, 1  $\mu$ A max. in shutdown
- High output voltage accuracy:  $\pm 0.5\%$  @ 25  $^{\circ}$ C,  $\pm 2.5\%$  across temperature range
- Output current up to 300 mA
- Fixed output voltage versions, starting from 1.2 V to 12 V with 100 mV step
- Adjustable voltage version, starting from 1.2 V to  $V_{IN} - V_{DROP}$
- Stable with low ESR capacitors (0.47  $\mu$ F min.)
- Thermal shutdown protection
- Current limit and SOA protection
- -40  $^{\circ}$ C to +125  $^{\circ}$ C operating temperature range

### Applications

- Post regulation
- Electronic meters
- Smoke detectors / alarms
- Portable equipment
- Industrial application

Maturity status link
ST732

### Description

The **ST730** is 300 mA LDO regulator, designed to be used in several medium voltage applications.

Ultra-low quiescent current of 5  $\mu$ A makes it suitable for applications permanently connected to power supply/battery.

This feature is also useful when electronic modules remain permanently turned on.

The **ST730** embeds protection functions, such as: current limit, short-circuit and thermal shutdown. The extended input voltage range, very low drop voltage and low quiescent current features make it suitable also for low power after-market automotive and consumer applications.

# 1 Schematic diagram

Figure 1. Block diagram - Fixed version

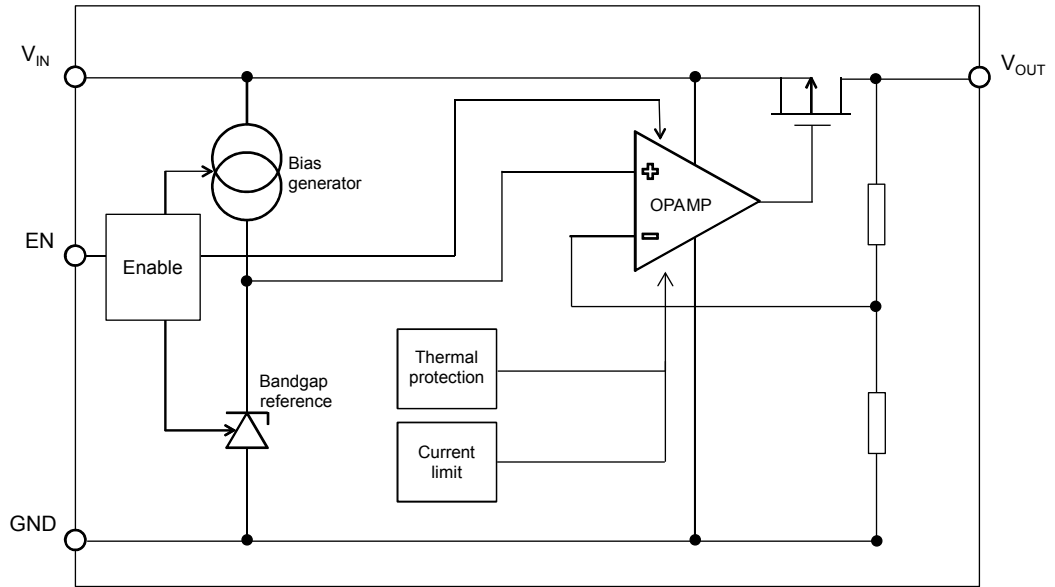
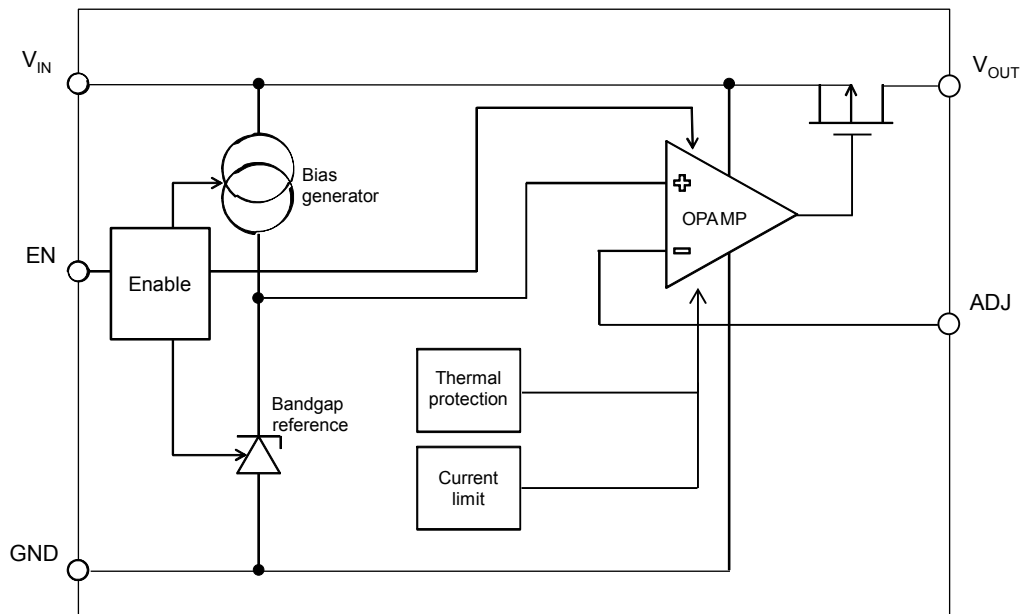


Figure 2. Block diagram - Adjustable version



## 2 Pin configuration

Figure 3. Pin connection (top view)

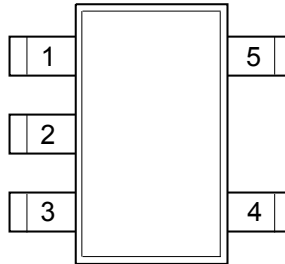


Table 1. Pin description

Pin	Symbol	Function
1	$V_{OUT}$	Regulated output voltage
2	GND	Ground
3	$V_{IN}$	Input voltage
4	NC/ADJ	Not internally connected in the fixed version. In the adjustable version, connect this pin to external resistor divider to set the output voltage
5	EN	Enable pin: Low = shutdown, High = active. Don't leave this pin floating

### 3 Typical application

Figure 4. Typical application circuit, fixed version

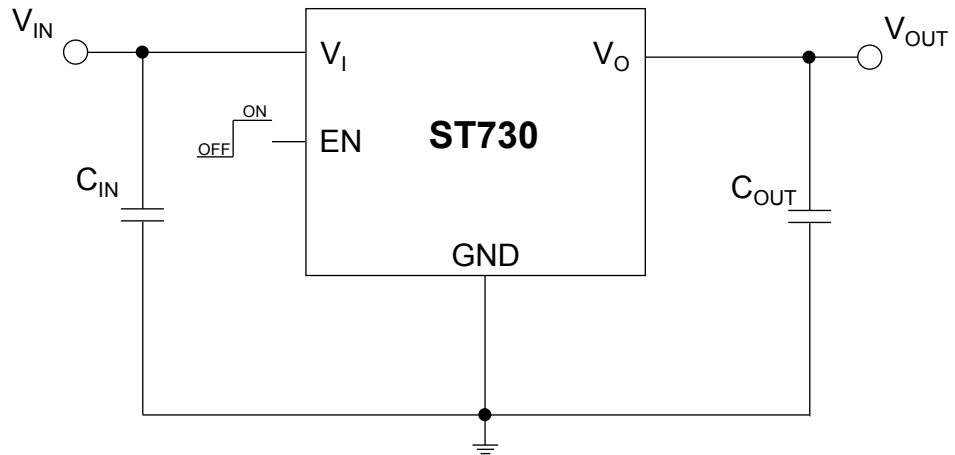
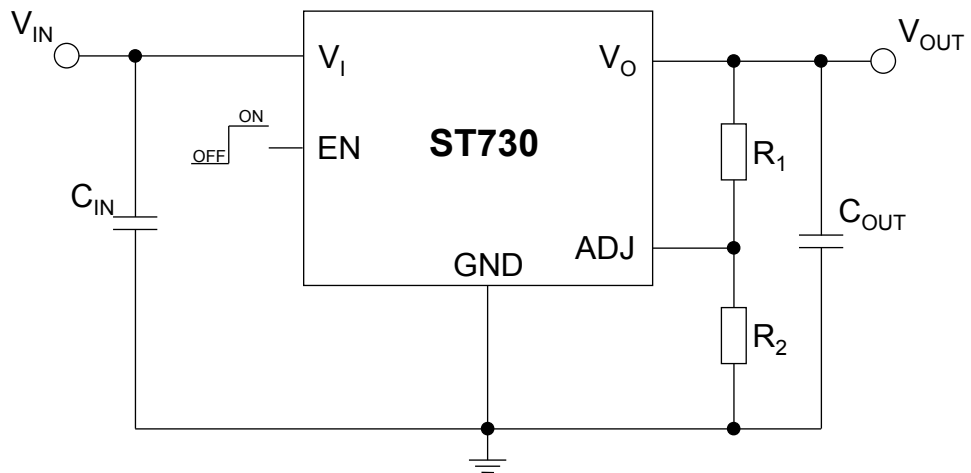


Figure 5. Typical application circuit, adjustable version



## 4 Maximum ratings

**Table 2. Absolute maximum ratings**

Symbol	Parameter	Value	Unit
$V_{IN}$	DC input voltage	-0.3 to 30	V
$V_{OUT}$	DC output voltage	-0.3 to $V_{IN} + 0.3$	V
$V_{EN}$	Enable pin voltage	-0.3 to 30	V
$V_{ADJ}$	Adjust pin voltage	-0.3 to 2.5	V
$I_{OUT}$	Output current	Internally limited	mA
$P_D$	Power dissipation	Internally limited	mW
$T_{ST}$	Storage temperature range	-65 to 150	°C
$T_{OP}$	Operating temperature range	-40 to 125	°C

**Note:** Absolute maximum ratings are those values beyond which damage to the device may occur. Functional operation under these conditions is not implied. All values are referred to GND.

**Table 3. Thermal data**

Symbol	Parameter	Value	Unit
$R_{thJA}$	Thermal resistance junction-ambient	190	°C/W
$R_{thJC}$	Thermal resistance junction-case	75	°C/W

**Note:**  $R_{thJA}$  based on 4-layer (2S2P) JEDEC test board constructed based on JESD 51-7 specification.

**Table 4. Electro static discharge**

Symbol	Parameter	Value	Unit
HBM	Human body model	±2	kV
CDM	Charged device model	±500	V

## 5 Electrical characteristics

$T_A = T_J = -40\text{ °C}$  to  $+125\text{ °C}$ , typical values refer to  $T_A = +25\text{ °C}$ ,  $V_{IN} = V_{EN} = V_{OUT} + 1\text{ V}$  <sup>(1)</sup>,  $I_{OUT} = 10\text{ mA}$ ,  $C_{IN} = 0.1\text{ }\mu\text{F}$ ,  $C_{OUT} = 0.47\text{ }\mu\text{F}$ , unless otherwise specified (see note).

**Table 5. Electrical characteristics for ST730, Fixed version**

Symbol	Parameter	Test conditions	Min.	Typ.	Max.	Unit
$V_{IN}$	Operating input voltage		2.5		28	V
$V_{OUT}$	Output voltage accuracy	$T_J = 25\text{ °C}$	-0.5		+0.5	%
		$-40\text{ °C} < T_J < +125\text{ °C}$	-2.5		+2.5	%
$\Delta V_{OUT}$	Static line regulation	$V_{IN} = V_{OUT(NOM)} + 1\text{ V}$ to $28\text{ V}$ <sup>(1)</sup>		0.003	0.05	%/V
$\Delta V_{OUT}$	Static load regulation	$I_{OUT} = 1\text{ mA}$ to $300\text{ mA}$ <sup>(2)</sup>		40	70	mV
$V_{DROP}$	Dropout voltage	$I_{OUT} = 100\text{ mA}$ , $V_{OUT} = V_{OUT(NOM)} - 0.1\text{ V}$ $V_{OUT(NOM)} \geq 2.5\text{ V}$		200	400	mV
		$I_{OUT} = 300\text{ mA}$ , $V_{OUT} = V_{OUT(NOM)} - 0.1\text{ V}$ $V_{OUT(NOM)} \geq 2.5\text{ V}$		600	1200	mV
$I_Q$	Quiescent current	$I_{OUT} = 0\text{ mA}$		5	10	$\mu\text{A}$
		$I_{OUT} = 300\text{ mA}$		120	240	
	Standby current	$V_{IN} = 2.5\text{ V}$ to $28\text{ V}$ , $V_{EN} = \text{GND}$		0.35	1	
$V_{EN}$	Enable input logic low				0.35	V
	Enable input logic high		1.2			V
$I_{EN}$	Enable pin current	$V_{EN} = V_{IN}$			100	nA
$e_N$	Output noise voltage <sup>(3)</sup>	$f = 10\text{ Hz}$ to $100\text{ kHz}$ , $I_{OUT} = 10\text{ mA}$ , $C_{OUT} = 1\text{ }\mu\text{F}$		70		$\mu\text{V}_{RMS}/V_{OUT}$
SVR	Supply voltage rejection <sup>(3)</sup>	$V_{IN} = V_{OUT(NOM)} + 1\text{ V} \pm V_{RIPPLE}$ , $V_{RIPPLE} = 0.5\text{ V}$ , $f = 120\text{ Hz}$ , $V_{OUT(NOM)} = 5\text{ V}$		75		dB
		$V_{IN} = V_{OUT(NOM)} + 1\text{ V} \pm V_{RIPPLE}$ , $V_{RIPPLE} = 0.5\text{ V}$ , $f = 1\text{ kHz}$ , $V_{OUT(NOM)} = 5\text{ V}$		75		
		$V_{IN} = V_{OUT(NOM)} + 1\text{ V} \pm V_{RIPPLE}$ , $V_{RIPPLE} = 0.5\text{ V}$ , $f = 10\text{ kHz}$ , $V_{OUT(NOM)} = 5\text{ V}$		42		
		$V_{IN} = V_{OUT(NOM)} + 1\text{ V} \pm V_{RIPPLE}$ , $V_{RIPPLE} = 0.5\text{ V}$ , $f = 100\text{ Hz}$ , $V_{OUT(NOM)} = 5\text{ V}$		35		
$I_{SC}$	Short-circuit current <sup>(4)</sup>	$R_L = 0$		450		mA
$T_{SHDN}$	Thermal shutdown <sup>(3)</sup>			160		$^{\circ}\text{C}$
	Hysteresis <sup>(3)</sup>			20		

- $V_{IN} = V_{OUT} + 1\text{ V}$  or  $2.5\text{ V}$ , whichever is greater.
- The device is able to properly regulate the output voltage with no load.
- Guaranteed by design, not tested in production.
- The current limit is a function of  $(V_{IN} - V_{OUT})$  differential during operation. Maximum available current is limited. Refer to [Section 6.1 External capacitors](#) for more information

**Note:** Values in full temperature range are guaranteed by design and/or characterization tested at  $T_A = \sim T_J$ . Low duty cycle pulse techniques are used.

$T_A = T_J = -40\text{ }^\circ\text{C}$  to  $+125\text{ }^\circ\text{C}$ , typical values refer to  $T_A = +25\text{ }^\circ\text{C}$ ,  $V_{IN} = V_{EN} = 2.5\text{ V}$ ,  $I_{OUT} = 10\text{ mA}$ ,  $C_{IN} = 0.1\text{ }\mu\text{F}$ ,  $C_{OUT} = 0.47\text{ }\mu\text{F}$ , unless otherwise specified (see note).

**Table 6. Electrical characteristics for ST730, Adjustable version**

Symbol	Parameter	Test conditions	Min.	Typ.	Max.	Unit
$V_{IN}$	Operating input voltage		2.5		28	V
$V_{ADJ}$	Reference voltage accuracy	$T_J = 25\text{ }^\circ\text{C}$	1.194		1.206	%
		$-40\text{ }^\circ\text{C} < T_J < +125\text{ }^\circ\text{C}$	-2		+2	%
$I_{ADJ}$	Adjust pin leakage current				100	nA
$\Delta V_{OUT}$	Static line regulation	$V_{IN} = 2.5\text{ V}$ to $28\text{ V}$		0.005	0.05	%/V
$\Delta V_{OUT}$	Static load regulation	$I_{OUT} = 1\text{ mA}$ to $300\text{ mA}$ <sup>(1)</sup>		0.001	0.003	%/mA
$I_Q$	Quiescent current	$I_{OUT} = 0\text{ mA}$		5	10	$\mu\text{A}$
		$I_{OUT} = 300\text{ mA}$		120	240	
	Standby current	$V_{IN} = 2.5\text{ V}$ to $28\text{ V}$ , $V_{EN} = \text{GND}$		0.35	1	
$V_{EN}$	Enable input logic low				0.35	V
	Enable input logic high		1.2			V
$I_{EN}$	Enable pin current	$V_{EN} = V_{IN}$			100	nA
$e_N$	Output noise voltage <sup>(2)</sup>	$f = 10\text{ Hz}$ to $100\text{ kHz}$ , $I_{OUT} = 10\text{ mA}$ , $C_{OUT} = 1\text{ }\mu\text{F}$		70		$\mu\text{V}_{\text{RMS}}/\text{V}_{\text{OUT}}$
SVR	Supply voltage rejection <sup>(2)</sup>	$V_{IN} = V_{OUT(\text{NOM})} + 1\text{ V} \pm V_{\text{RIPPLE}}$ , $V_{\text{RIPPLE}} = 0.5\text{ V}$ , $f = 120\text{ Hz}$ , $V_{OUT(\text{NOM})} = 5\text{ V}$		75		dB
		$V_{IN} = V_{OUT(\text{NOM})} + 1\text{ V} \pm V_{\text{RIPPLE}}$ , $V_{\text{RIPPLE}} = 0.5\text{ V}$ , $f = 1\text{ kHz}$ , $V_{OUT(\text{NOM})} = 5\text{ V}$		75		
		$V_{IN} = V_{OUT(\text{NOM})} + 1\text{ V} \pm V_{\text{RIPPLE}}$ , $V_{\text{RIPPLE}} = 0.5\text{ V}$ , $f = 10\text{ kHz}$ , $V_{OUT(\text{NOM})} = 5\text{ V}$		42		
		$V_{IN} = V_{OUT(\text{NOM})} + 1\text{ V} \pm V_{\text{RIPPLE}}$ , $V_{\text{RIPPLE}} = 0.5\text{ V}$ , $f = 100\text{ Hz}$ , $V_{OUT(\text{NOM})} = 5\text{ V}$		35		
$I_{SC}$	Short-circuit current <sup>(3)</sup>	$R_L = 0$		450		mA
$T_{\text{SHDN}}$	Thermal shutdown <sup>(2)</sup>			160		$^\circ\text{C}$
	Hysteresis <sup>(2)</sup>			20		

1. The device is able to properly regulate the output voltage with no load.
2. Guaranteed by design, not tested in production.
3. The current limit is a function of  $(V_{IN} - V_{OUT})$  differential during operation. Maximum available current is limited. Refer to Section 6.4 Protection features for more information.

**Note:** Values in full temperature range are guaranteed by design and/or characterization tested at  $T_A = \sim T_J$ . Low duty cycle pulse techniques are used.

## 6 Application information

### 6.1 External capacitors

The ST730 voltage regulator requires external capacitors to ensure the control loop stability. These capacitors must be selected to meet the requirements of minimum capacitance and equivalent series resistance defined in the following chapters. Input and output capacitors should be located as close as possible to the relevant pins.

#### Input capacitor

An input capacitor, whose minimum value is 0.1  $\mu\text{F}$ , must be placed as close as possible to the input in of the device and returned to a clean analog ground. A good quality, low-ESR ceramic capacitor is suggested. It helps to ensure stability of the control loop, reduces the effects of inductive sources and improves ripple rejection. Values, which are higher than 0.1  $\mu\text{F}$ , are suggested in case of fast load transients in the application. There is no maximum limit to the output capacitance. An input capacitor, whose minimum value is 0.1  $\mu\text{F}$ , must be placed as close as possible to the input in of the device and returned to a clean analog ground. A good quality, low-ESR ceramic capacitor is suggested. It helps to ensure stability of the control loop, reduces the effects of inductive sources and improves ripple rejection. Values, which are higher than 0.1  $\mu\text{F}$ , are suggested in case of fast load transients in the application. There is no maximum limit to the output capacitance.

#### Output capacitor

The ST730 requires a capacitor connected on its output, to keep the control loop stable and reduce the risk of ringing and oscillations. The control loop is designed to be stable with any good quality ceramic capacitor (such as X5R/X7R types) with a minimum value of 0.47  $\mu\text{F}$  and equivalent series resistance in the [5 – 500 m $\Omega$ ] range. It is important to highlight that the output capacitor must maintain its capacitance and ESR in the stable region over the full operating temperature, load and input voltage ranges, to assure stability. Therefore, capacitance and ESR variations must be taken into account in the design phase to ensure the device works in the expected stability region.

There is no maximum limit to the output capacitance, provided that the above conditions are satisfied.

### 6.2 Output voltage adjustment

In the adjustable version the output voltage can be adjusted to any voltage, starting from 1.2 V ( $V_{ADJ}$ ) up to the input voltage minus the voltage drop ( $V_{DROP}$ ) across the internal power pass element, by connecting a resistor divider between the ADJ pin and the output, allowing the remote voltage sensing.

The resistor divider should be selected using the following equation:

$$V_{OUT} = V_{ADJ}(1 + R_1/R_2) \quad (1)$$

with  $V_{ADJ} = 1.2 \text{ V}$  (typ.) and  $V_{OUT} < V_{IN} - V_{DROP(MAX)}$

For best accuracy and stability the resistor divider should be designed in order to allow that a current of at least 500 nA flows across it. The current flowing into the ADJ pin is typically less than 10 nA, therefore it causes negligible change in the final output voltage.

### 6.3 Power dissipation

A proper PCB design is recommended, to ensure that the device internal junction temperature is kept below 125 °C, in all the operating condition. The thermal energy generated by the device flows from the die surface to the PCB copper area through the package leads. The PCB copper area acts as a heat sink. The footprint copper pads should be as wider as possible to spread and dissipate the heat to the surrounding environment. Thermal micro-vias to the inner or backside copper layers improve the overall thermal performance of the device.

The power dissipation of the LDO depends on the input voltage, output voltage and output current, and is given by:

$$P_D = (V_{IN} - V_{OUT}) I_{OUT} \quad (2)$$

The junction temperature of the device is:

$$T_{J\_MAX} = T_A + R_{thJA} \times P_D \quad (3)$$



where:  $T_{J\_MAX}$  is the maximum junction of the die, 125 °C;  $T_A$  is the ambient temperature;  $R_{thJA}$  is the thermal resistance junction-to-ambient.

With the above equation it is possible to calculate the maximum allowable power dissipation, therefore the maximum load current for a certain voltage drop. Appropriate de-rating of the operating condition can be applied accordingly.

## 6.4 Protection features

### Current limit

Due to the wide input voltage range, high power dissipation could occur in case of damaged/shorted load. For this reason the ST730 embeds a SOA protection-current limit circuit, which acts in case of overload or short-circuit on the output, clamping the load current to a safe value.

The current limit value is purposely made depended on the voltage drop ( $V_{IN} - V_{OUT}$ ), so that the maximum dissipated power is always kept under control.

The non-constant current limit characteristic shown in [Figure 18. Short circuit current vs. dropout voltage](#) should be taken into account to calculate the maximum load current the device can supply for a certain dropout voltage.

Normal operation is restored if the overload disappears, but prolonged operation in current limit may lead to high power dissipation inside the LDO and subsequently to thermal shutdown.

### Thermal protection

An internal thermal feedback loop disables the output voltage if the die temperature reaches approximately 160 °C. This feature protects the device from excessive temperature that could lead to permanent damage to the LDO.

Once the thermal protection is triggered and the device is shut down, normal operation is automatically recovered if the die temperature falls below 140 °C (thermal protection hysteresis of 20 °C typically).

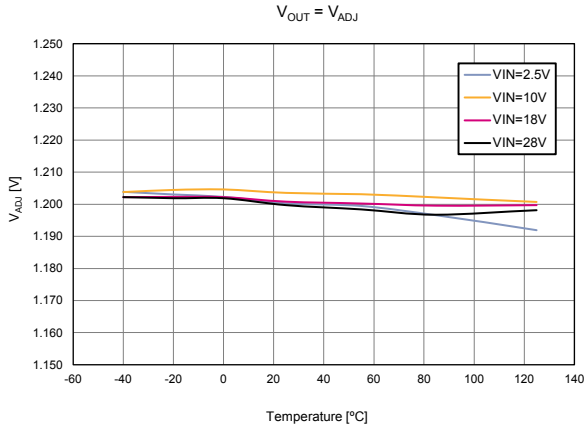
Continuous operation above the maximum ratings may lead to permanent damage to the device.

In case of operation with strongly inductive loads, undershoots on the output may happen. If those negative spikes overcome the absolute maximum ratings of the device, permanent damage may occur. A schottky diode connected in parallel to the output port reduces the risk of damages in such operating cases.

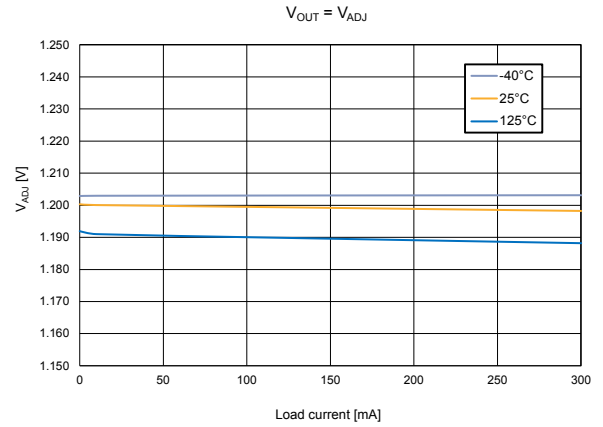
## 7 Typical performance characteristics

$C_{IN} = C_{OUT} = 1 \mu\text{F}$ ,  $V_{IN} = 2.5 \text{ V}$ ,  $V_{OUT} = V_{ADJ}$ ,  $T_J = 25 \text{ }^\circ\text{C}$ , unless otherwise specified.

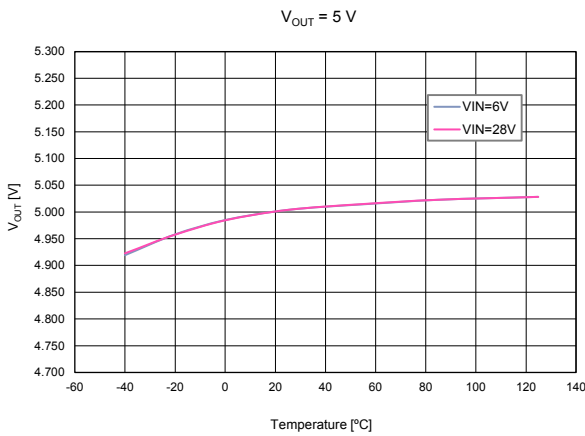
**Figure 6. Reference voltage vs. temperature, no load**



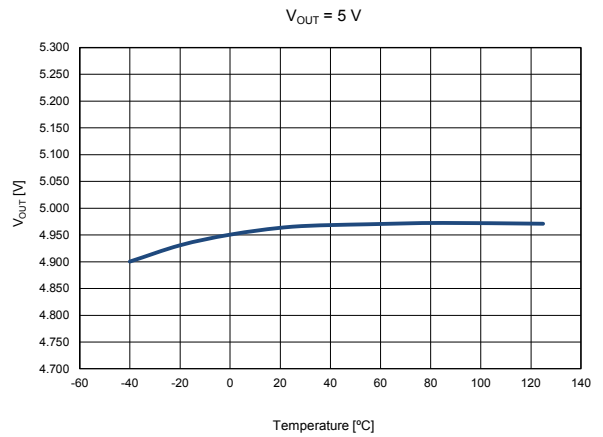
**Figure 7. Reference voltage vs. load current and temperature**

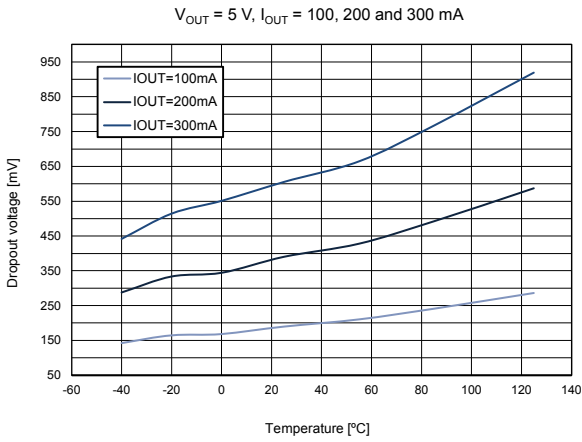
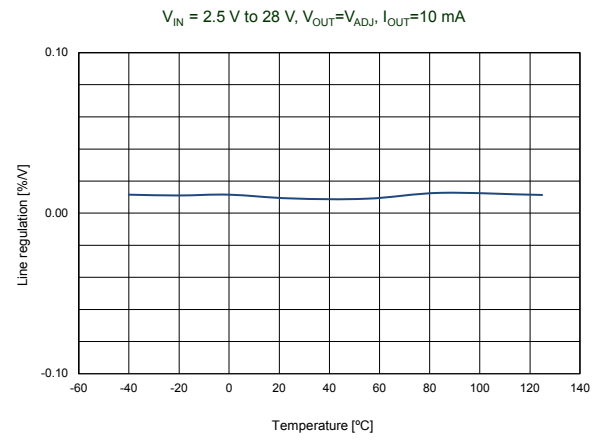
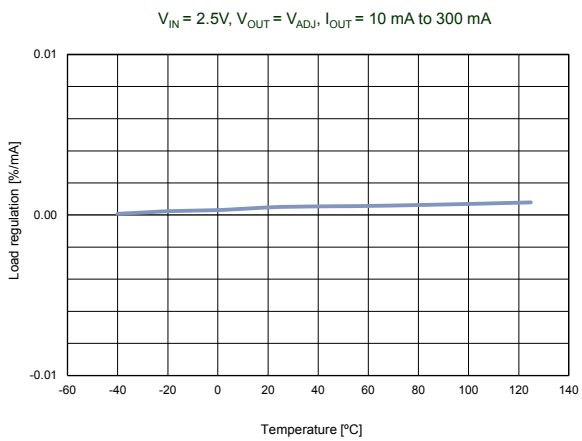
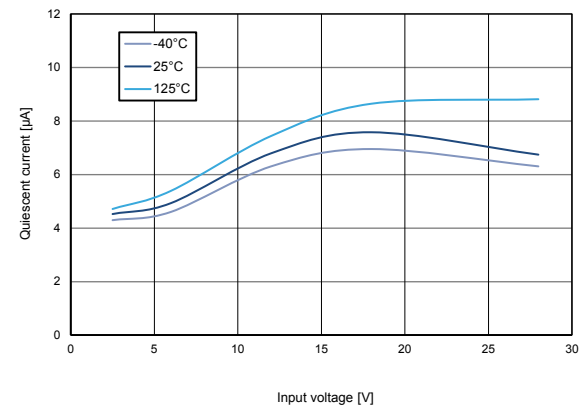


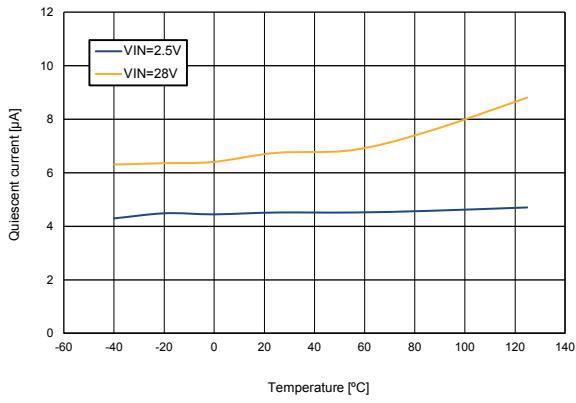
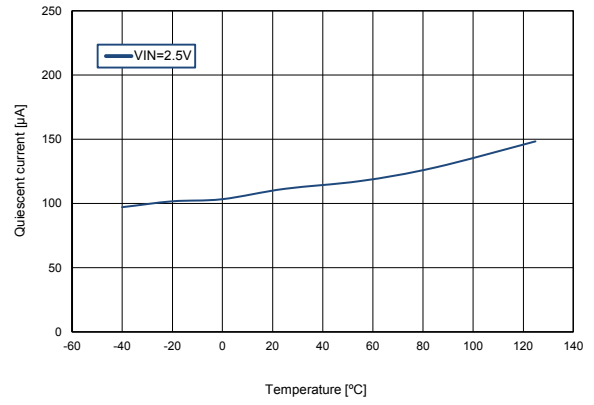
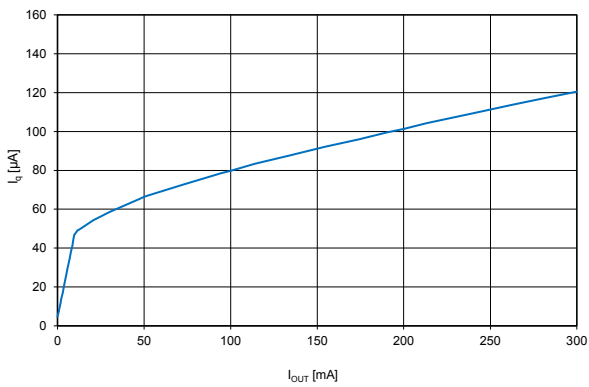
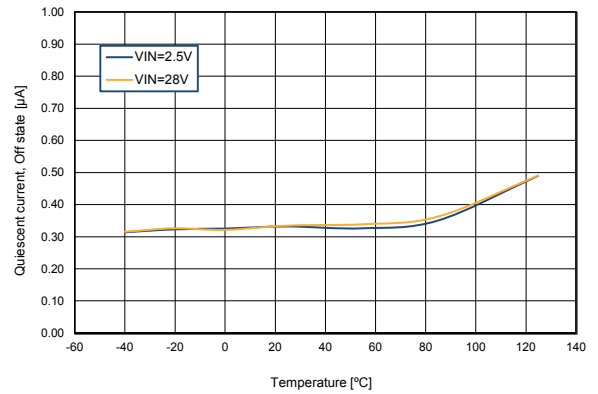
**Figure 8. Output voltage vs. temperature**

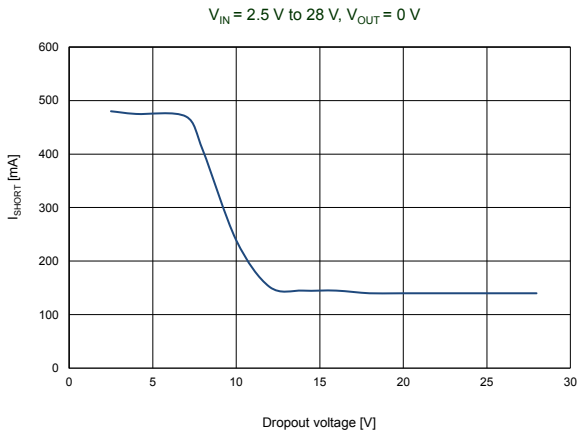
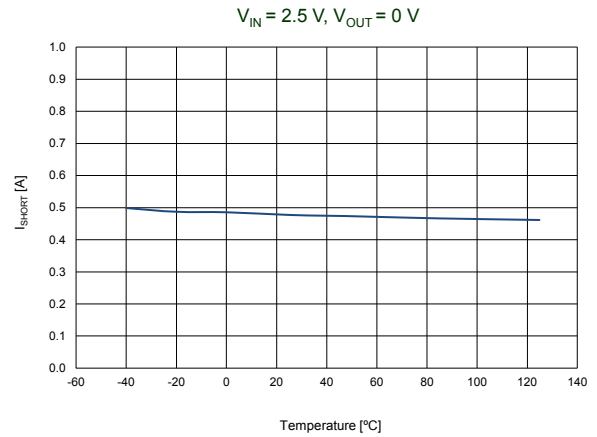
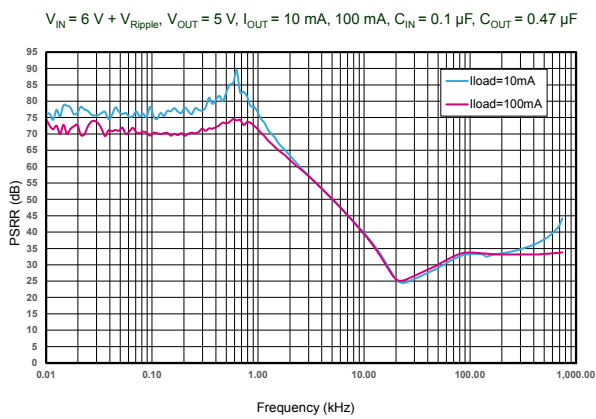
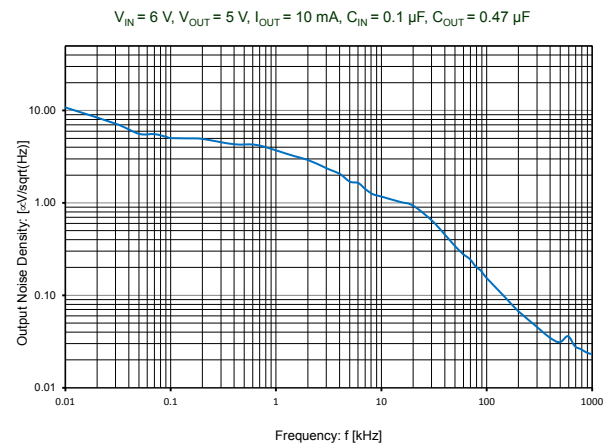


**Figure 9. Output voltage vs. temperature ( $I_{OUT} = 300 \text{ mA}$ )**

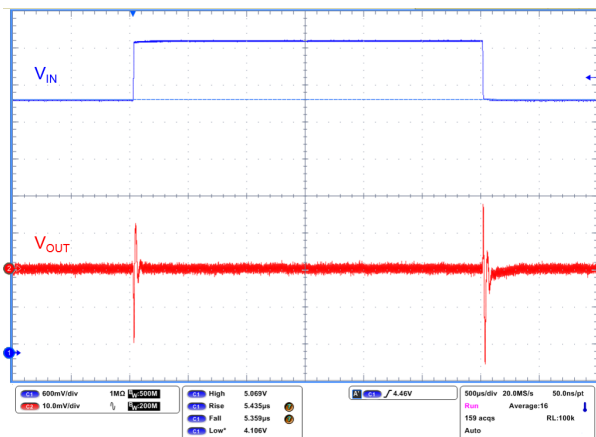


**Figure 10. Dropout voltage vs. temperature**

**Figure 11. Line regulation vs. temperature**

**Figure 12. Load regulation vs. temperature**

**Figure 13. Quiescent current vs. input voltage ( $I_{OUT} = 0\text{ mA}$ )**


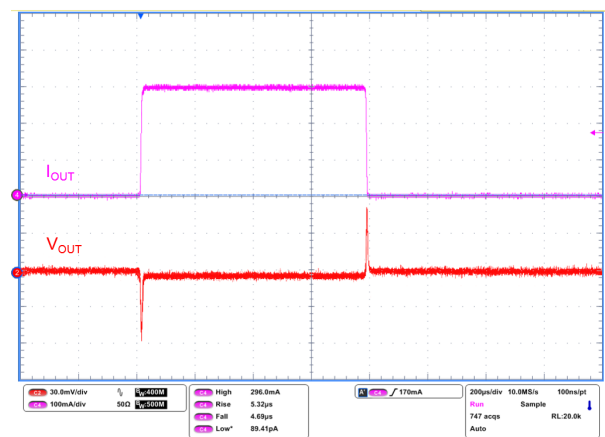
**Figure 14. Quiescent current vs. temperature**  
 ( $I_{OUT} = 0 \text{ mA}$ )

**Figure 15. Quiescent current vs. temperature**  
 ( $I_{OUT} = 300 \text{ mA}$ )

**Figure 16. Quiescent current vs. load current**
 $V_{IN} = 2.5 \text{ V}$ ,  $V_{OUT} = V_{ADJ}$ ,  $I_{OUT} = 0 \text{ mA}$  to  $300 \text{ mA}$ 

**Figure 17. Standby current vs. temperature**
 $V_{EN} = \text{GND}$ 


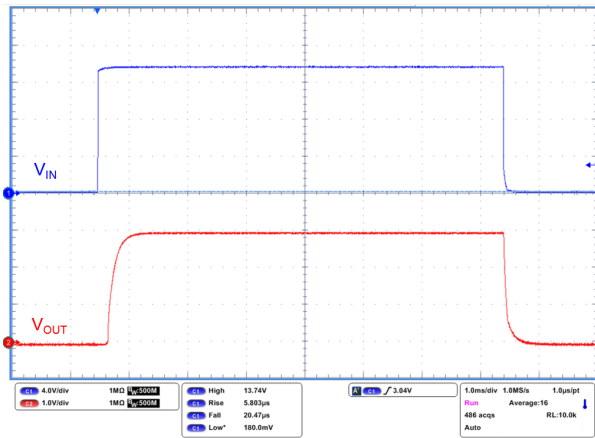
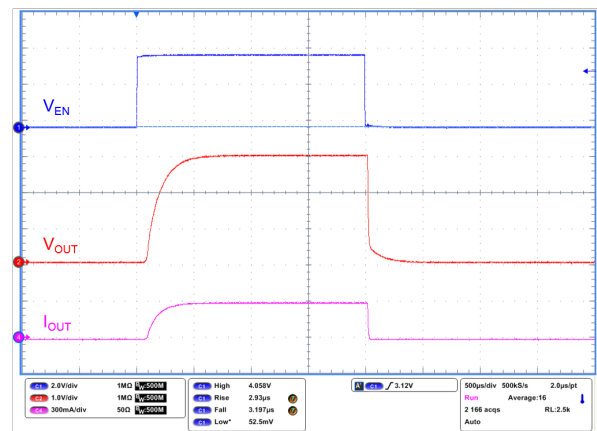
**Figure 18. Short circuit current vs. dropout voltage**

**Figure 19. Current limit vs. temperature**

**Figure 20. PSRR vs. frequency**

**Figure 21. Output noise spectrum**

**Figure 22. Line transient**

$V_{IN} = 4\text{ V to }5\text{ V}, V_{OUT} = 3.0\text{ V}, I_{OUT} = 10\text{ mA}, t_r = t_f = 5\text{ }\mu\text{s}, C_{IN} = 0.1\text{ }\mu\text{F}, C_{OUT} = 0.47\text{ }\mu\text{F}$


**Figure 23. Load transient**

$V_{IN} = 2.5\text{ V}, V_{OUT} = 1.2\text{ V}, I_{OUT} = 10\text{ mA to }300\text{ mA}, t_r = 5\text{ }\mu\text{s}, C_{IN} = 0.1\text{ }\mu\text{F}, C_{OUT} = 10\text{ }\mu\text{F}$



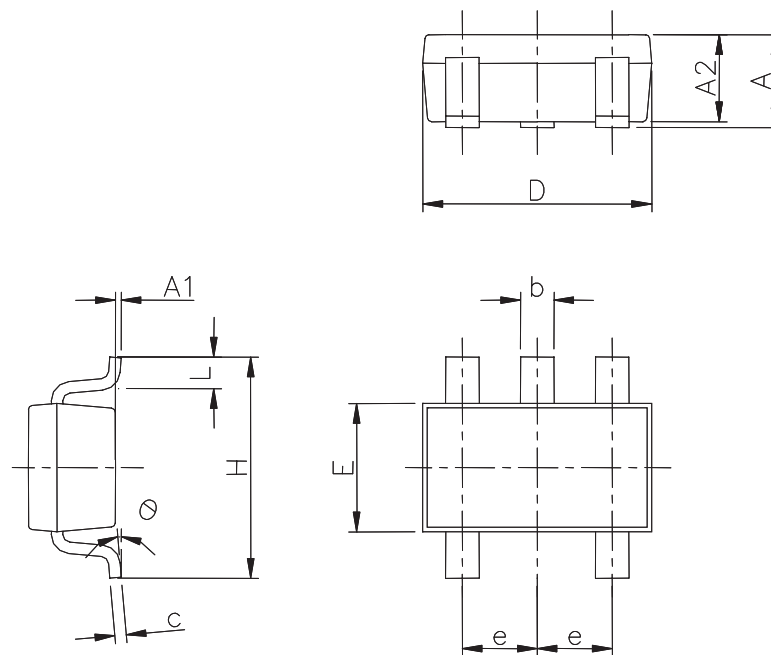
**Figure 24. Startup transient**
 $V_{IN} = 0\text{ V to }14\text{ V}$ ,  $V_{OUT} = 3.0\text{ V}$ ,  $I_{OUT} = 10\text{ mA}$ ,  $t_r = 5\text{ }\mu\text{s}$ ,  $C_{IN} = 0.1\text{ }\mu\text{F}$ ,  $C_{OUT} = 0.47\text{ }\mu\text{F}$ 

**Figure 25. Enable transient**
 $V_{IN} = 4\text{ V}$ ,  $V_{EN} = 0\text{ to }V_{IN}$ ,  $V_{OUT} = 3.0\text{ V}$ ,  $I_{OUT} = 300\text{ mA}$ ,  $t_r = 5\text{ }\mu\text{s}$ ,  $C_{IN} = 0.1\text{ }\mu\text{F}$ ,  $C_{OUT} = 0.47\text{ }\mu\text{F}$ 


## 8 Package information

In order to meet environmental requirements, ST offers these devices in different grades of **ECOPACK** packages, depending on their level of environmental compliance. ECOPACK specifications, grade definitions and product status are available at: [www.st.com](http://www.st.com). ECOPACK is an ST trademark.

### 8.1 SOT23-5L package information

Figure 26. SOT23-5L package outline

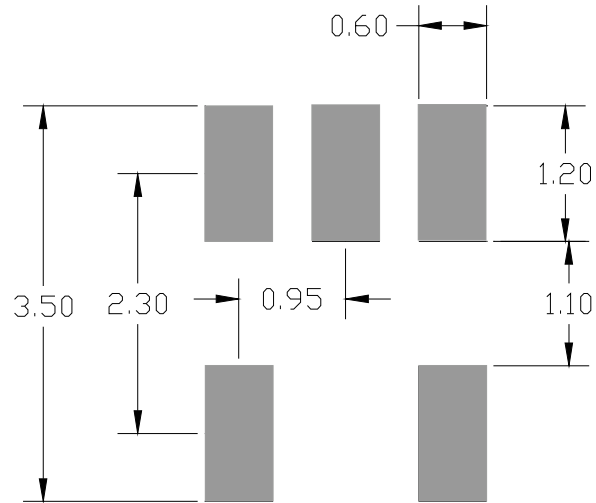


7049676

Table 7. SOT23-5L package mechanical data

Dimension	mm		
	Min.	Typ.	Max.
A	0.90		1.45
A1	0		0.15
A2	0.90		1.30
b	0.30		0.50
c	0.09		0.20
D		2.95	
E		1.60	
e		0.95	
H		2.80	
L	0.30		0.60
$\theta$	0		10

Figure 27. SOT23-5L recommended footprint

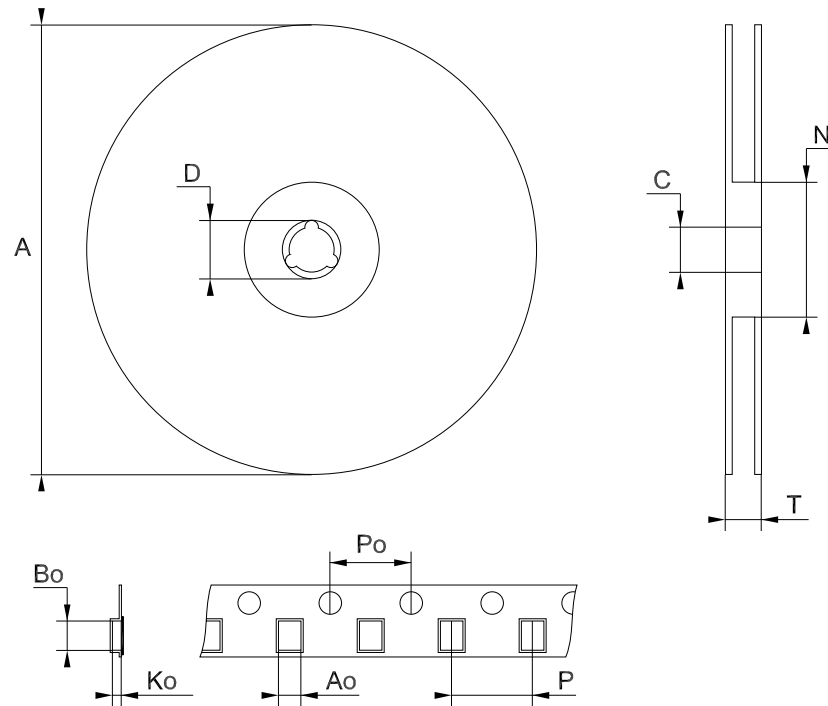


Note: Dimensions are in mm



## 8.2 Packing information

Figure 28. SOT23-5L tape and reel drawing



Note: Drawing not in scale

Table 8. SOT23-5L tape and reel mechanical data

Dimension	mm		
	Min.	Typ.	Max.
A			180
C	12.8	13.0	13.2
D	20.2		
N	60		
T			14.4
Ao		3.15	
Bo		3.2	
Ko		1.4	
Po	3.9	4.0	4.1
P	3.9	4.0	4.1
W	7.9	8	8.3

## 9 Ordering information

**Table 9. Order code**

Order code	Output voltage	Marking
ST730M28R	2.8 V	028
ST730M30R <sup>(1)</sup>	3.0 V	030
ST730M33R	3.3 V	033
ST730M36R	3.6 V	036
ST730M50R	5.0 V	050
ST730MR	Adjustable	0AD

1. Available on request

*Note:* Other voltage options can be available on request. Contact local sales office.

## Revision history

**Table 10. Document revision history**

Date	Revision	Changes
17-Jun-2019	1	Initial release.
18-Feb-2020	2	Updated $V_{OUT}$ , $\Delta V_{OUT}$ values in Table 5 and $V_{ADJ}$ values in Table 6.
15-Jun-2020	3	Added new order codes in Order code.
22-Apr-2021	4	Added new order codes in <a href="#">Table 9</a>

## Contents

<b>1</b>	<b>Schematic diagram</b> .....	<b>2</b>
<b>2</b>	<b>Pin configuration</b> .....	<b>3</b>
<b>3</b>	<b>Typical application</b> .....	<b>4</b>
<b>4</b>	<b>Maximum ratings</b> .....	<b>5</b>
<b>5</b>	<b>Electrical characteristics</b> .....	<b>6</b>
<b>6</b>	<b>Application information</b> .....	<b>8</b>
6.1	External capacitors .....	8
6.2	Output voltage adjustment .....	8
6.3	Power dissipation .....	8
6.4	Protection features .....	9
<b>7</b>	<b>Typical performance characteristics</b> .....	<b>10</b>
<b>8</b>	<b>Package information</b> .....	<b>15</b>
8.1	SOT23-5L package information.....	15
8.2	Packing information .....	17
<b>9</b>	<b>Ordering information</b> .....	<b>18</b>
	<b>Revision history</b> .....	<b>19</b>

## List of tables

<b>Table 1.</b>	Pin description . . . . .	3
<b>Table 2.</b>	Absolute maximum ratings . . . . .	5
<b>Table 3.</b>	Thermal data . . . . .	5
<b>Table 4.</b>	Electro static discharge . . . . .	5
<b>Table 5.</b>	Electrical characteristics for ST730, Fixed version . . . . .	6
<b>Table 6.</b>	Electrical characteristics for ST730, Adjustable version . . . . .	7
<b>Table 7.</b>	SOT23-5L package mechanical data . . . . .	15
<b>Table 8.</b>	SOT23-5L tape and reel mechanical data . . . . .	17
<b>Table 9.</b>	Order code . . . . .	18
<b>Table 10.</b>	Document revision history . . . . .	19

## List of figures

<b>Figure 1.</b>	Block diagram - Fixed version . . . . .	2
<b>Figure 2.</b>	Block diagram - Adjustable version . . . . .	2
<b>Figure 3.</b>	Pin connection (top view) . . . . .	3
<b>Figure 4.</b>	Typical application circuit, fixed version . . . . .	4
<b>Figure 5.</b>	Typical application circuit, adjustable version . . . . .	4
<b>Figure 6.</b>	Reference voltage vs. temperature, no load . . . . .	10
<b>Figure 7.</b>	Reference voltage vs. load current and temperature . . . . .	10
<b>Figure 8.</b>	Output voltage vs. temperature . . . . .	10
<b>Figure 9.</b>	Output voltage vs. temperature ( $I_{OUT} = 300\text{ mA}$ ) . . . . .	10
<b>Figure 10.</b>	Dropout voltage vs. temperature . . . . .	11
<b>Figure 11.</b>	Line regulation vs. temperature . . . . .	11
<b>Figure 12.</b>	Load regulation vs. temperature . . . . .	11
<b>Figure 13.</b>	Quiescent current vs. input voltage ( $I_{OUT} = 0\text{ mA}$ ) . . . . .	11
<b>Figure 14.</b>	Quiescent current vs. temperature ( $I_{OUT} = 0\text{ mA}$ ) . . . . .	12
<b>Figure 15.</b>	Quiescent current vs. temperature ( $I_{OUT} = 300\text{ mA}$ ) . . . . .	12
<b>Figure 16.</b>	Quiescent current vs. load current . . . . .	12
<b>Figure 17.</b>	Standby current vs. temperature . . . . .	12
<b>Figure 18.</b>	Short circuit current vs. dropout voltage . . . . .	13
<b>Figure 19.</b>	Current limit vs. temperature . . . . .	13
<b>Figure 20.</b>	PSRR vs. frequency . . . . .	13
<b>Figure 21.</b>	Output noise spectrum . . . . .	13
<b>Figure 22.</b>	Line transient . . . . .	13
<b>Figure 23.</b>	Load transient . . . . .	13
<b>Figure 24.</b>	Startup transient . . . . .	14
<b>Figure 25.</b>	Enable transient . . . . .	14
<b>Figure 26.</b>	SOT23-5L package outline . . . . .	15
<b>Figure 27.</b>	SOT23-5L recommended footprint . . . . .	16
<b>Figure 28.</b>	SOT23-5L tape and reel drawing . . . . .	17

**IMPORTANT NOTICE – PLEASE READ CAREFULLY**

STMicroelectronics NV and its subsidiaries (“ST”) reserve the right to make changes, corrections, enhancements, modifications, and improvements to ST products and/or to this document at any time without notice. Purchasers should obtain the latest relevant information on ST products before placing orders. ST products are sold pursuant to ST’s terms and conditions of sale in place at the time of order acknowledgement.

Purchasers are solely responsible for the choice, selection, and use of ST products and ST assumes no liability for application assistance or the design of Purchasers’ products.

No license, express or implied, to any intellectual property right is granted by ST herein.

Resale of ST products with provisions different from the information set forth herein shall void any warranty granted by ST for such product.

ST and the ST logo are trademarks of ST. For additional information about ST trademarks, please refer to [www.st.com/trademarks](http://www.st.com/trademarks). All other product or service names are the property of their respective owners.

Information in this document supersedes and replaces information previously supplied in any prior versions of this document.

© 2021 STMicroelectronics – All rights reserved