

Latchable Negative Floating Hot Swap Power Manager

FEATURES

- Precision Fault Threshold
- Programmable:
Average Power Limiting, Linear Current Control, Overcurrent Limit and Fault Time
- Fault Output Indication Signal
- Automatic Retry Mode or Latched Operation Mode
- Shutdown Control
- Undervoltage Lockout
- 250µs Glitch Filter on the SDFLTCH pin
- 8-Pin DIL and SOIC

DESCRIPTION

The UCC3921 family of negative floating hot swap power managers provides complete power management, hot swap, and fault handling capability. The IC is referenced to the negative input voltage and is powered through an external resistor connected to ground, which is essentially a current drive as opposed to the traditional voltage drive. The onboard 10V shunt regulator protects the IC from excess voltage and serves as a reference for programming the maximum allowable output sourcing current during a fault. All control and housekeeping functions are integrated and externally programmable. These include the fault current level, maximum output sourcing current, maximum fault time, selection of Retry or Latched mode, soft start time, and average power limiting. In the event of a constant fault, the internal timer will limit the on time from less than 0.1% to a maximum of 3% duty cycle. The duty cycle modulation depends on the current into PL, which is a function of the voltage across the FET, thus limiting average power dissipation in the FET. The fault level is fixed at 50mV across the current sense amplifier to minimize total

(continued)

BLOCK DIAGRAM

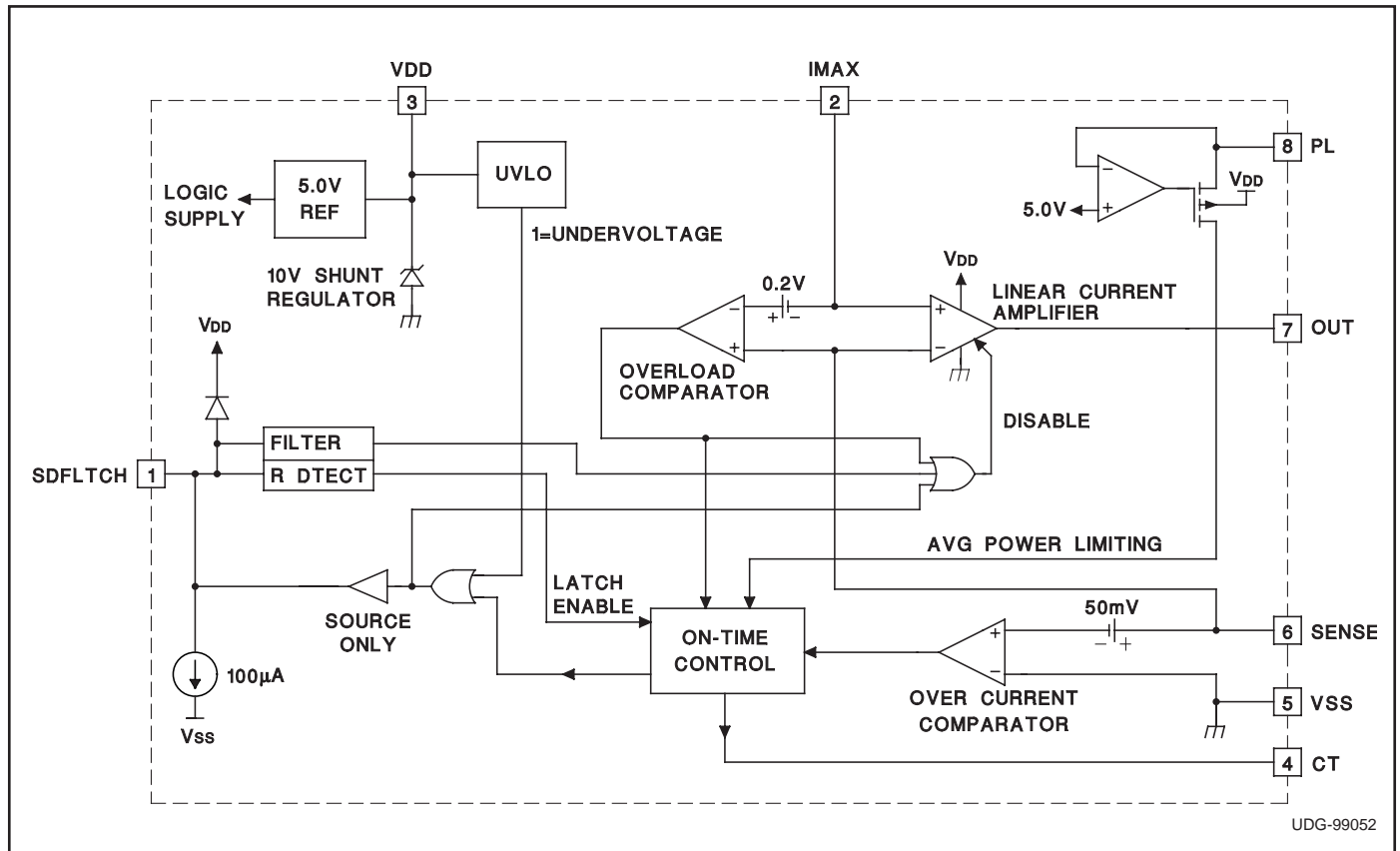

DESCRIPTION (continued)

dropout. The fault current level is set with an external current sense resistor, while the maximum allowable sourcing current is programmed with a voltage divider from VDD to generate a fixed voltage on IMAX. The current level, when the output acts as a current source, is equal to V_{IMAX}/R_{SENSE} . If desired, a controlled current start up can be programmed with a capacitor on IMAX.

When the output current is below the fault level, the output device is switched on. When the output current exceeds the fault level, but is less than the maximum sourcing level programmed by IMAX, the output remains switched on, and the fault timer starts charging CT. Once

CT charges to 2.5V, the output device is turned off and performs a retry some time later (provided that the selected mode of operation is Automatic Retry Mode). When the output current reaches the maximum sourcing current level, the output acts as a current source, limiting the output current to the set value defined by IMAX.

Other features of the UCC3921 include undervoltage lockout, 8-pin Small Outline (SOIC) and Dual-In-Line (DIL) packages, and a Latched Operation Mode option, in which the output is latched off once CT charges to 2.5V and stays off until either SDFLTCH is toggled (for greater than 1ms) or the IC is powered down and then back up.

ABSOLUTE MAXIMUM RATINGS

I _{VDD}	50mA
SDFLTCH Current	10mA
PL Current	10mA
IMAX Input Voltage	VDD
Storage Temperature	-65°C to +150°C
Junction Temperature	-55°C to +150°C
Lead Temperature (Soldering, 10 sec.)	+300°C

All voltages are with respect to V_{SS} (the most negative voltage). Currents are positive into, negative out of the specified terminal. Consult Packaging Section of Databook for thermal limitations and considerations of packages.

CONNECTION DIAGRAM

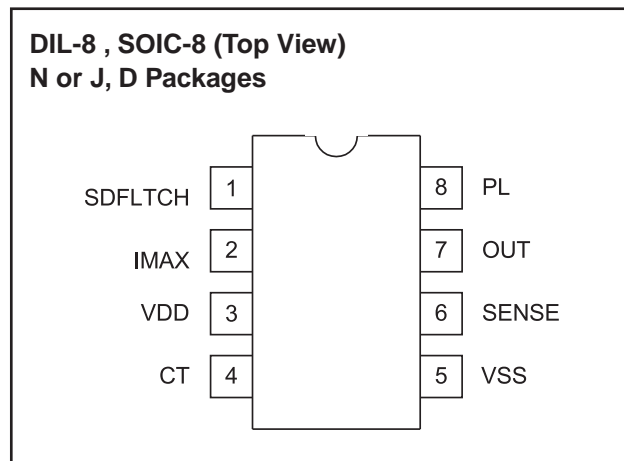

ELECTRICAL CHARACTERISTICS Unless otherwise specified, T_A = 0°C to 70°C for the UCC3921 and -40°C to 85°C for the UCC2921, and -55°C to 125°C for the UCC1921; I_{VDD} = 2mA, C_T = 1nF (the minimum allowable value), there is no resistor connected between the SDFLTCH and VSS pins. T_A = T_J.

PARAMETER	TEST CONDITIONS	MIN	TYP	MAX	UNITS
VDD Section					
IDD			1	2	mA
Regulator Voltage	I _{SOURCE} = 2mA	9	9.5	10.0	V
	I _{SOURCE} = 10mA	9.15	9.6	10.15	V
UVLO Off Voltage		6	7	8	V
Fault Timing Section					
Overcurrent Threshold	T _J = 25°C	47.5	50	53.5	mV
	Over Operating Temperature	46	50	53.5	mV
Overcurrent Input Bias			50	500	nA
CT Charge Current	V _{CT} = 1V, I _{PL} = 0	-50	-36	-22	μA
	Overload Condition, V _{SENSE} - V _{IMAX} = 300mV	-1.7	-1.2	-0.7	mA
CT Discharge Current	V _{CT} = 1V, I _{PL} = 0	0.6	1	1.5	μA
CT Fault Threshold		2.2	2.45	2.6	V
CT Reset Threshold		0.41	0.49	0.57	V
Output Duty Cycle	Fault Condition, I _{PL} = 0	1.7	2.7	3.7	%

ELECTRICAL CHARACTERISTICS Unless otherwise specified, $T_A = 0^\circ\text{C}$ to 70°C for the UCC3921 and -40°C to 85°C for the UCC2921, and -55°C to 125°C for the UCC1921; $I_{VDD} = 2\text{mA}$, $C_T = 1\text{nF}$ (the minimum allowable value), there is no resistor connected between the SDFLTCH and VSS pins. $T_A = T_J$.

PARAMETER	TEST CONDITIONS	MIN	TYP	MAX	UNITS
Output Section					
Output High Voltage	$I_{OUT} = 0\text{mA}$	8.5	10		V
	$I_{OUT} = -1\text{mA}$	6	8		V
Output Low Voltage	$I_{OUT} = 0\text{mA}$, $V_{SENSE} - V_{IMAX} = 100\text{mV}$		0	10	mV
	$I_{OUT} = 2\text{mA}$, $V_{SENSE} - V_{IMAX} = 100\text{mV}$		200	600	mV
Linear Amplifier Section					
Sense Control Voltage	$V_{IMAX} = 100\text{mV}$	85	100	115	mV
	$V_{IMAX} = 400\text{mV}$	370	400	430	mV
Input Bias			50	500	nA
Power Limiting Section					
VSENSE Regulator Voltage	$I_{PL} = 64\mu\text{A}$	4.35	4.85	5.35	V
Duty Cycle Control	$I_{PL} = 64\mu\text{A}$	0.6	1.2	1.7	%
	$I_{PL} = 1\text{mA}$	0.045	0.1	0.17	%
Overload Section					
Delay to Output	Note 1		300	500	ns
Output Sink Current	$V_{SENSE} - V_{IMAX} = 300\text{mV}$	40	100		mA
Threshold	Relative to IMAX	140	200	260	mV
Shutdown/Fault/Latch Section					
Shutdown Threshold		3	5	VDD+1	V
Input Current	$V_{SDFLTCH} = 5\text{V}$	50	110	250	μA
Filter Delay Time (Delay to Output)		250	500	1000	μs
Fault Output High		6	9.5		V
	$I_{SDFLTCH} = -100\mu\text{A}$	5	8.5		V
Fault Output Low			0	10	mV
Output Duty Cycle	Fault Condition, $I_{PL} = 0$	1.7	2.7	3.7	%
	$I_{SDFLTCH} = -100\mu\text{A}$, Fault Condition, $I_{PL} = 0$			0	%

Note 1: Guaranteed by design. Not 100% tested in production.

PIN DESCRIPTIONS

CT: A capacitor is connected to this pin in order to set the fault time. The fault time must be longer than the time to charge external load capacitance. The fault time is defined as:

$$T_{FAULT} = \frac{2 \cdot C_T}{I_{CH}}$$

where $I_{CH} = 36\mu\text{A} + I_{PL}$, and I_{PL} is the current into the power limit pin. Once the maximum fault time is reached the output will shutdown for a time given by:

$$T_{SD} = 2 \cdot 10^6 \cdot C_T$$

IMAX: This pin programs the maximum allowable sourcing current. Since VDD is a regulated voltage, a voltage divider can be derived from VDD to generate the program level for IMAX. The current level at which the output appears as a current source is equal to the

voltage on IMAX over the current sense resistor. If desired, a controlled current start up can be programmed with a capacitor on IMAX, and a programmed start delay can be achieved by driving the shutdown with an open collector/drain device into an RC network.

OUT: This pin provides gate output drive to the MOSFET pass element.

PL: This feature ensures that the average MOSFET power dissipation is controlled. A resistor is connected from this pin to the drain of the NMOS pass element. When the voltage across the NMOS exceeds 5V, current will flow into the PL pin which adds to the fault timer charge current, reducing the duty cycle from the 3% level. When $I_{PL} \gg 36\mu\text{A}$, then the average MOSFET power dissipation is given by:

$$P_{MOSFET\text{avg}} = IMAX \cdot 1 \cdot 10^{-6} \cdot R_{PL}$$

PIN DESCRIPTIONS (continued)

SENSE: Input voltage from the current sense resistor. When there is greater than 50mV across this pin with respect to VSS, then a fault is sensed, and C_T starts to charge.

SDFLTCH: This pin provides fault output indication, shutdown control, and operating mode selection. Interface into and out of this pin is usually performed through level shift transistors. When open, and under a non-fault condition, this pin pulls to a low state with respect to VSS. When a fault is detected by the fault timer, or undervoltage lockout, this pin will drive to a high state with respect to VSS, indicating the NMOS pass element is OFF. When $> 250\mu A$ is sourced into this pin for $> 1ms$, it drives high causing the output to disable the NMOS pass device.

If an $5k < R_{LATCH} < 250k\Omega$ resistor is placed from this pin to VSS, then the latched operating mode will be invoked. Upon the occurrence of a fault, under the latched mode of operation, once the C_T capacitor charges up to 2.5V the NMOS pass element latches off. A retry will not periodically occur. To reset the latched off device, either SDFLTCH is toggled high for a duration greater than 1ms or the IC is powered down and then up.

VDD: Current driven with a resistor to a voltage approximately 10V more positive than VSS. Typically a resistor is connected to ground. The 10V shunt regulator clamps VDD approximately 10V above VSS, and is also used as an output reference to program the maximum allowable sourcing current.

VSS: Ground reference for the IC and the most negative voltage available.

APPLICATION INFORMATION

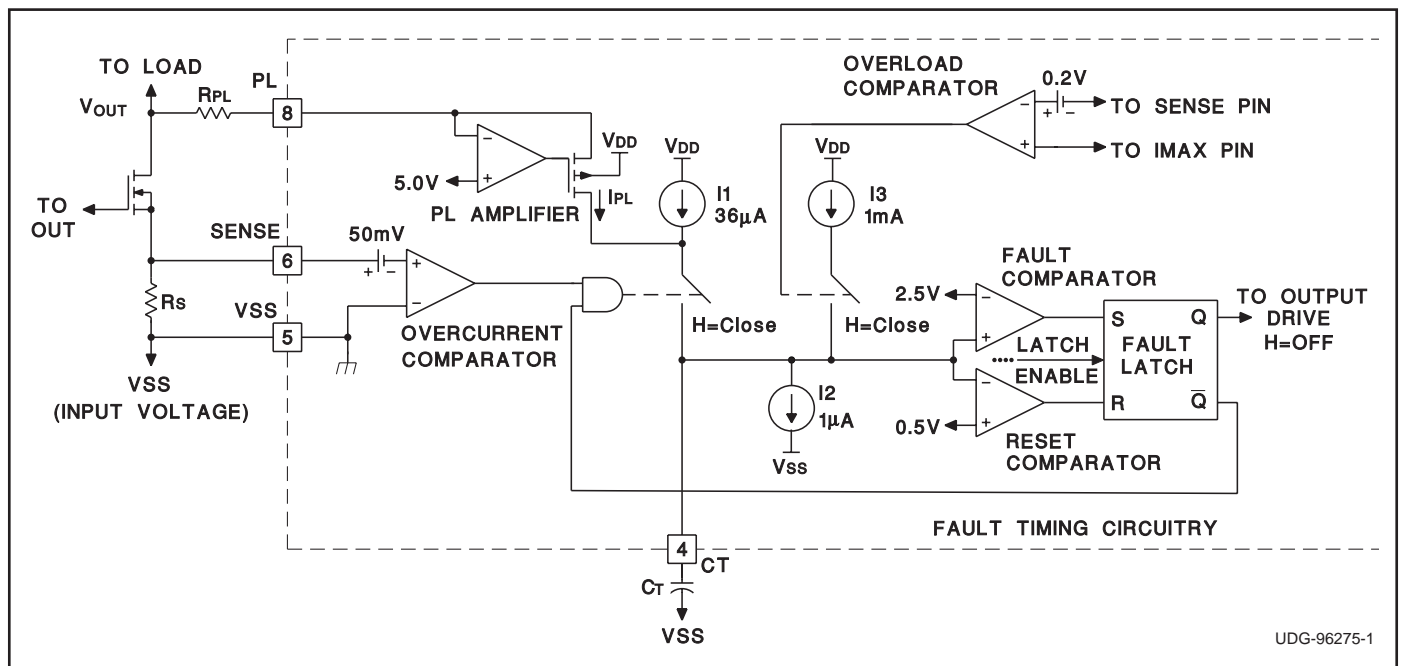

Figure 1. Fault Timing Circuitry for the UCC3921, Including Power Limit Overload

APPLICATION INFORMATION (continued)

Figure 1 shows the detailed circuitry for the fault timing function of the UCC3921. For the time being, we will discuss a typical fault mode, therefore, the overload comparator, and current source I3 does not work into the operation. Once the voltage across the current sense resistor, R_s , exceeds 50mV, a fault has occurred. This causes the timing capacitor to charge with a combination of 36 μ A plus the current from the power limiting amplifier. The PL amplifier is designed to only source current into the CT pin and to begin sourcing current once the voltage across the output FET exceeds 5V. The current I_{PL}

is related to the voltage across the FET with the following expression:

$$I_{PL} = \frac{V_{FET} - 5V}{R_{PL}}$$

where V_{FET} is the voltage across the NMOS pass device. Later it will be shown how this feature will limit average power dissipation in the pass device. Note that under a condition where the output current is more than the fault level, but less than the max level, $V_{OUT} \approx V_{SS}$ (input voltage), $I_{PL} = 0$, the CT charging current is 36 μ A.

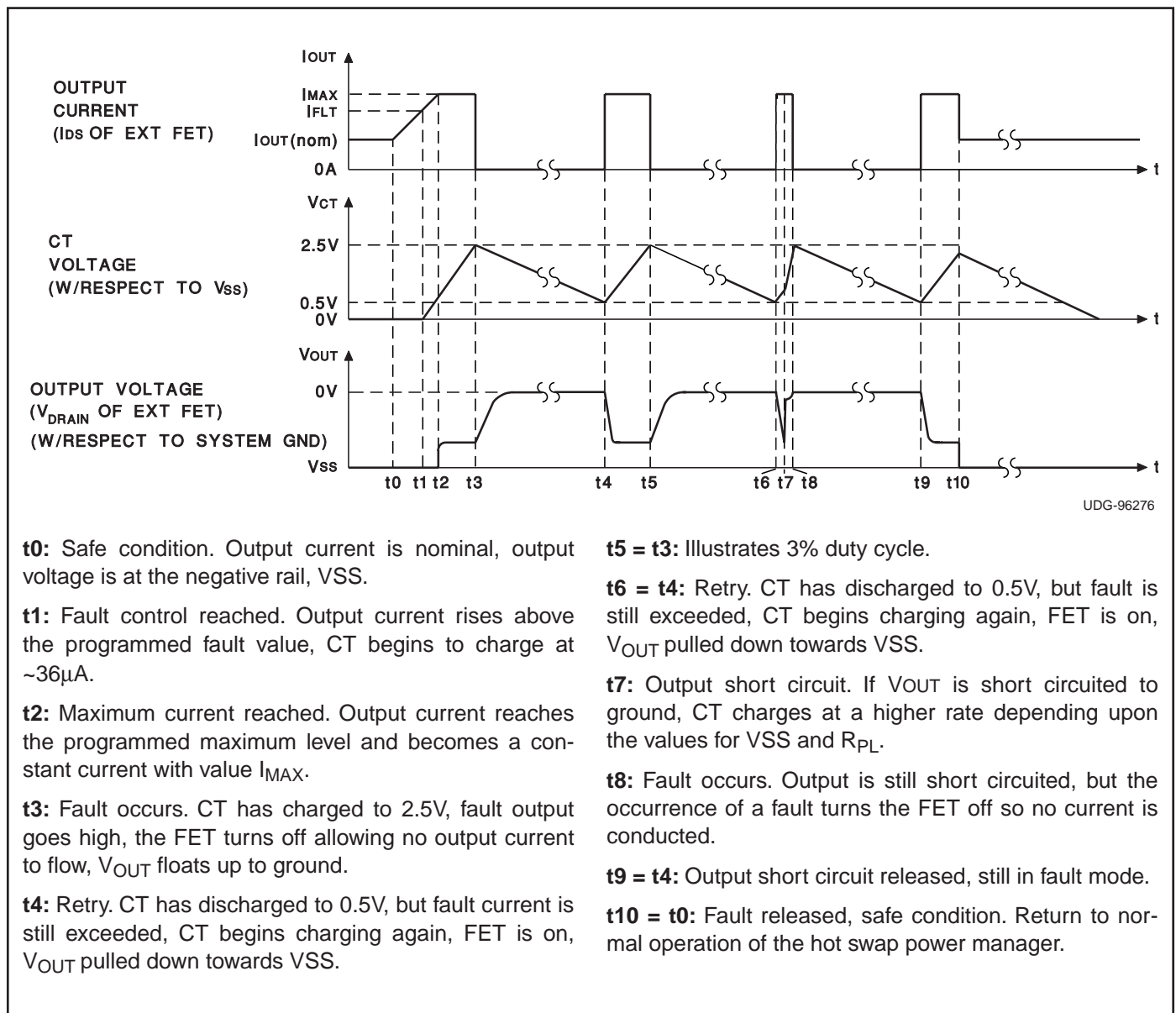
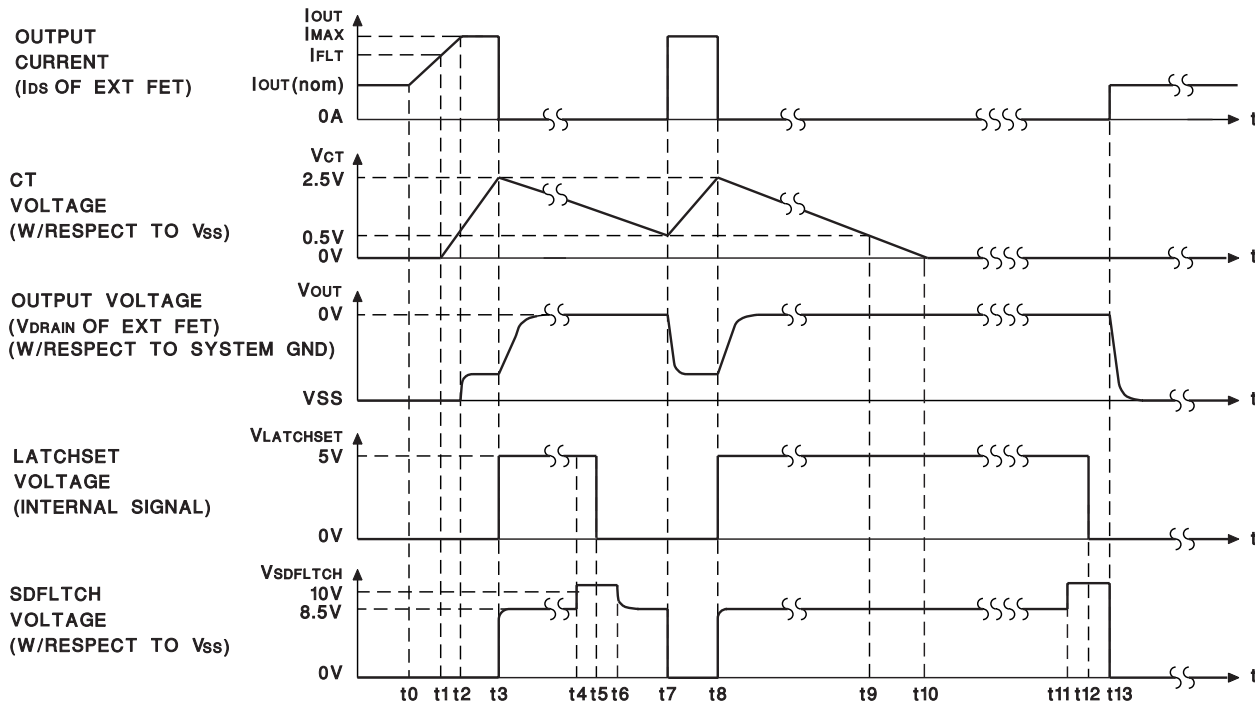

Figure 2. Retry Operation Mode

APPLICATION INFORMATION (cont.)



UDG-96277

t₀: Safe condition. Output current is nominal, output voltage is at the negative rail, V_{SS}.

t₁: Fault control reached. Output current rises above the programmed fault value, CT begins to charge at ~36μA.

t₂: Maximum current reached. Output current reaches the programmed maximum level and becomes a constant current with value I_{MAX}.

t₃: Fault occurs. CT has charged to 2.5V, fault output goes high as indicated by the SDFLTCH voltage. The FET turns off allowing no output current to flow, V_{OUT} floats up to ground, and since there is an 82kΩ resistor from the SDFLTCH pin to V_{SS}, the internal latchset signal goes high.

t₄: Since the user does not want the chip to LATCH off during this cycle, he toggles SDFLTCH high for greater than 1ms {t₆ - t₄ > 1ms}.

t₅: The latchset signal is reset.

t₆: Forcing of SDFLTCH is released after having been applied for > 1ms.

t₇: Retry (since the latchset signal has been reset to its' low state) - CT has discharged to 0.5V, but fault current

is still exceeded, CT begins charging again, FET is on, V_{OUT} pulled down towards V_{SS}.

t₈ = t₃: Fault occurs. CT has charged to 2.5V, fault output goes high as indicated by the SDFLTCH voltage, the FET turns off allowing no output current to flow, V_{OUT} floats up to ground, and since there is an 82kΩ resistor from SDFLTCH to V_{SS}, the internal latchset signal goes high.

t₉: Output is latched off. Even though CT has discharged to 0.5V, there will not be a retry since the latchset signal was allowed to remain high.

t₁₀: Output remains latched off. CT has discharged all the way to 0V.

t₁₁: The output has been latched off for quite some time. The user now wishes to reset the latched off output, thus toggling SDFLTCH high for greater than 1ms {t₁₃ - t₁₁}.

t₁₂ = t₅: The latchset signal is reset.

t₁₃: Forcing of SDFLTCH is released after having been applied for > 1ms. The fault had also been released during the time the output was latched off, safe condition, return to normal operation of the hot swap power manager.

Figure 3. Latched Operation Mode: R_{LATCH} = 82k

APPLICATION INFORMATION (continued)

During a fault, CT will charge at a rate determined by the internal charging current and the external timing capacitor. Once CT charges to 2.5V, the fault comparator switches and sets the fault latch. Setting of the fault latch causes both the output to switch off and the charging switch to open. CT must now discharge with the 1μA current source, I2, until 0.5V is reached. Once the voltage at CT reaches 0.5V, the fault latch resets, which re-enables the output and allows the fault circuitry to regain control of the charging switch. If a fault is still present, the fault comparator will close the charging switch causing the cycle to repeat. Under a constant fault, the duty cycle is given by:

$$\text{Duty Cycle} = \frac{1\mu\text{A}}{I_{PL} + 36\mu\text{A}}$$

Average power dissipation in the pass element is given by:

$$P_{FET_{AVG}} = V_{FET} \cdot I_{MAX} \cdot \frac{1\mu\text{A}}{I_{PL} + 36\mu\text{A}}$$

Where $V_{FET} \gg 5V$ I_{PL} can be approximated as:

$$\frac{V_{FET}}{R_{PL}}$$

and where $I_{PL} \gg 36\mu\text{A}$, the duty cycle can be approximated as :

$$\frac{1\mu\text{A} \cdot R_{PL}}{V_{FET}}$$

Therefore, the maximum average power dissipation in the MOSFET can be approximated by:

$$\begin{aligned} P_{FET_{AVG}} &= V_{FET} \cdot I_{MAX} \cdot \frac{1\mu\text{A} \cdot R_{PL}}{V_{FET}} \\ &= I_{MAX} \cdot 1\mu\text{A} \cdot R_{PL} \end{aligned}$$

Notice that in the approximation, V_{FET} cancels, thereby limiting the average power dissipation in the NMOS pass element.

Overload Comparator

The linear amplifier in the UCC3921 ensures that the output NMOS does not pass more than I_{MAX} (which is V_{IMAX}/R_{SENSE}). In the event the output current exceeds the programmed I_{MAX} by $0.2V/R_{SENSE}$, which can only occur if the output FET is not responding to a command from the IC, CT will begin charging with I3, 1mA, and continue to charge to approximately 8V. This allows a constant fault to show up on the SDFLTCH pin, and also since the voltage on CT will continue charging past 2.5V in an overload fault mode, it can be used for detection of

output FET failure or to build redundancy into the system.

Determining External Component Values

To set R_{VDD} (see Fig. 4) the following must be achieved:

$$\frac{V_{IN \text{ min}}}{R_{VDD}} > \frac{10V}{R1 + R2} + 2mA$$

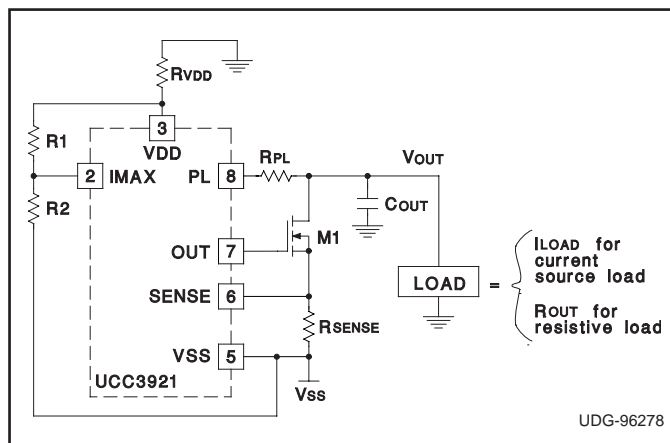

Figure 4.

In order to estimate the minimum timing capacitor, C_T , several things must be taken into account. For example, given the schematic in Figure 4 as a possible (and at this point, a standard) application, certain external component values must be known in order to estimate C_{TMIN} . Now, given the values of C_{OUT} , Load, R_{SENSE} , V_{SS} , and the resistors determining the voltage on the IMAX pin, the user can calculate the approximate startup time of the node V_{OUT} . This startup time must be faster than the time it takes for C_T to charge to 2.5V (relative to V_{SS}), and is the basis for estimating the minimum value of C_T . In order to determine the value of the sense resistor, R_{SENSE} , assuming the user has determined the fault current, R_{SENSE} can be calculated by:

$$R_{SENSE} = \frac{50mV}{I_{FAULT}}$$

Next, the variable I_{MAX} must be calculated. I_{MAX} is the maximum current that the UCC3921 will allow through the transistor, M1, and it can be shown that during startup with an output capacitor the power MOSFET, M1, can be modeled as a constant current source of value I_{MAX} where

$$I_{MAX} = \frac{V_{IMAX}}{R_{SENSE}} \text{ where } V_{IMAX} = \text{voltage on pin IMAX.}$$

Given this information, calculation of the startup time is now possible via the following:

APPLICATION INFORMATION (continued)

Current Source Load:

$$T_{START} = \frac{C_{OUT} \cdot |V_{SS}|}{I_{MAX} - I_{LOAD}}$$

Resistive Load:

$$T_{START} = \frac{C_{OUT} \cdot R_{OUT} \cdot \ln\left(\frac{I_{MAX} \cdot R_{OUT}}{I_{MAX} \cdot R_{OUT} - |V_{SS}|}\right)}{5 \cdot R_{PL}}$$

Once T_{START} is calculated, the power limit feature of the UCC3921 must be addressed and component values derived. Assuming the user chooses to limit the maximum

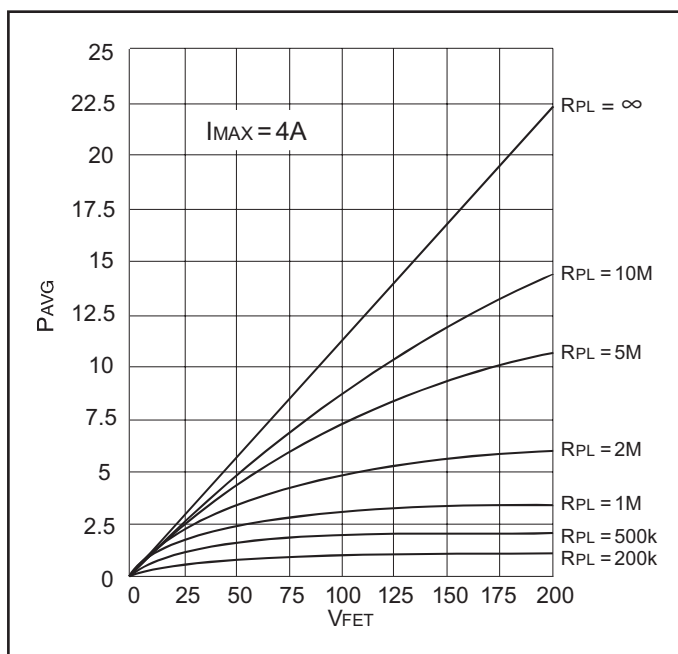

Figure 5. Plot Average Power vs FET Voltage for Increasing Values of R_{PL}

allowable average power that will be associated with the hot swap power manager, the power limiting resistor, R_{PL} , can be easily determined by the following:

$$R_{PL} = \frac{P_{FET\ avg}}{1\mu A \cdot I_{MAX}}$$

defined by $R_{PL\ min} = \frac{|V_{SS}|}{5mA}$ (Refer to Figure 5).

Finally, after computing the aforementioned variables, the minimum timing capacitor can be derived as such:

Current Source Load:

$C_T\ min =$

$$\frac{3 \cdot T_{START} \cdot (72\mu A \cdot R_{PL} + |V_{SS}| - 10V)}{10 \cdot R_{PL}}$$

Resistive Load:

$C_T\ min =$

$$\frac{3 \cdot T_{START} \cdot (36\mu A \cdot R_{PL} + |V_{SS}| - 5V - I_{MAX} \cdot R_{OUT})}{5 \cdot R_{PL}} + \frac{3 \cdot R_{OUT} \cdot |V_{SS}| \cdot C_{OUT}}{5 \cdot R_{PL}}$$

Level Shift Circuitry to Interface with SDFLTCH

Some type of circuit is needed to interface with the UCC3921 via SDFLTCH, such as opto-couplers or level shift circuitry. Figure 6 depicts one implementation of level shift circuitry that could be used, showing component values selected for a typical $-48V$ telecommunication application. There are three communication conditions which could occur; two of which are Hot Swap Power Manager (HSPM) state output indications, and the third being an External Shutdown.

- 1) When open, and under a non-fault condition, SDFLTCH is pulled to a low state. In Figure 6, the N-channel level shift transistor is off, and the FAULT OUT signal is pulled to LOCAL VDD through R3. This indicates that the HSPM is not faulted.
- 2) When a fault is detected by the fault timer or under-voltage lockout, this pin will drive to a high state, indicating that the external power FET is off. In Figure 6, the N-channel level shift transistor will conduct, and the FAULT OUT signal will be pulled to a Schottky Diode voltage drop below LOCAL GND. This indicates that the HSPM is faulted. The Schottky Diode is necessary to ensure that the FAULT OUT signal does not traverse too far below LOCAL GND, making fault detection difficult.

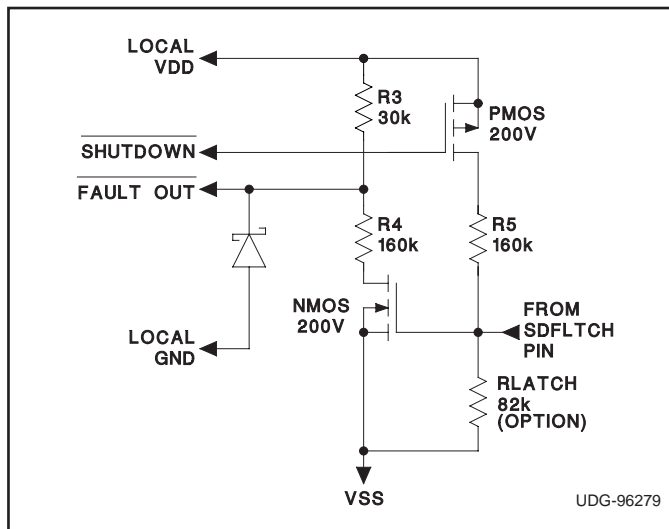

Figure 6. Possible Level Shift Circuitry to Interface to the UCC3921, showing component values selected for a typical telecom application.

APPLICATION INFORMATION (continued)

If a $5k < R_{LATCH} < 250k\Omega$ resistor is tied between SDFLTCH & VSS, as optionally shown in Figure 6, then the latched operating mode (described earlier) will be invoked upon the occurrence of a fault.

- 3) To externally shutdown the HSPM, the SHUTDOWN signal (typically held at LOCAL VDD) must be pulled to LOCAL GND. Assuming SHUTDOWN is tied to LOCAL GND, the P-channel level shift transistor will conduct, driving SDFLTCH high (to roughly VDD plus a diode). By sourcing $> 250\mu A$ into SDFLTCH for $> 1ms$ the output to the external power FET will be disabled. The current sourced into SDFLTCH must be

limited to 10mA or less: $ISDFLTCHMAX < 10mA$.

SAFETY RECOMMENDATIONS

Although the UCC3921 is designed to provide system protection for all fault conditions, all integrated circuits can ultimately fail short. For this reason, if the UCC3921 is intended for use in safety critical applications where UL® or some other safety rating is required, a redundant safety device such as a fuse should be placed in series with the external power FET. The UCC3921 will prevent the fuse from blowing for virtually all fault conditions, increasing system reliability and reducing maintenance cost, in addition to providing the hot swap benefits of the device.

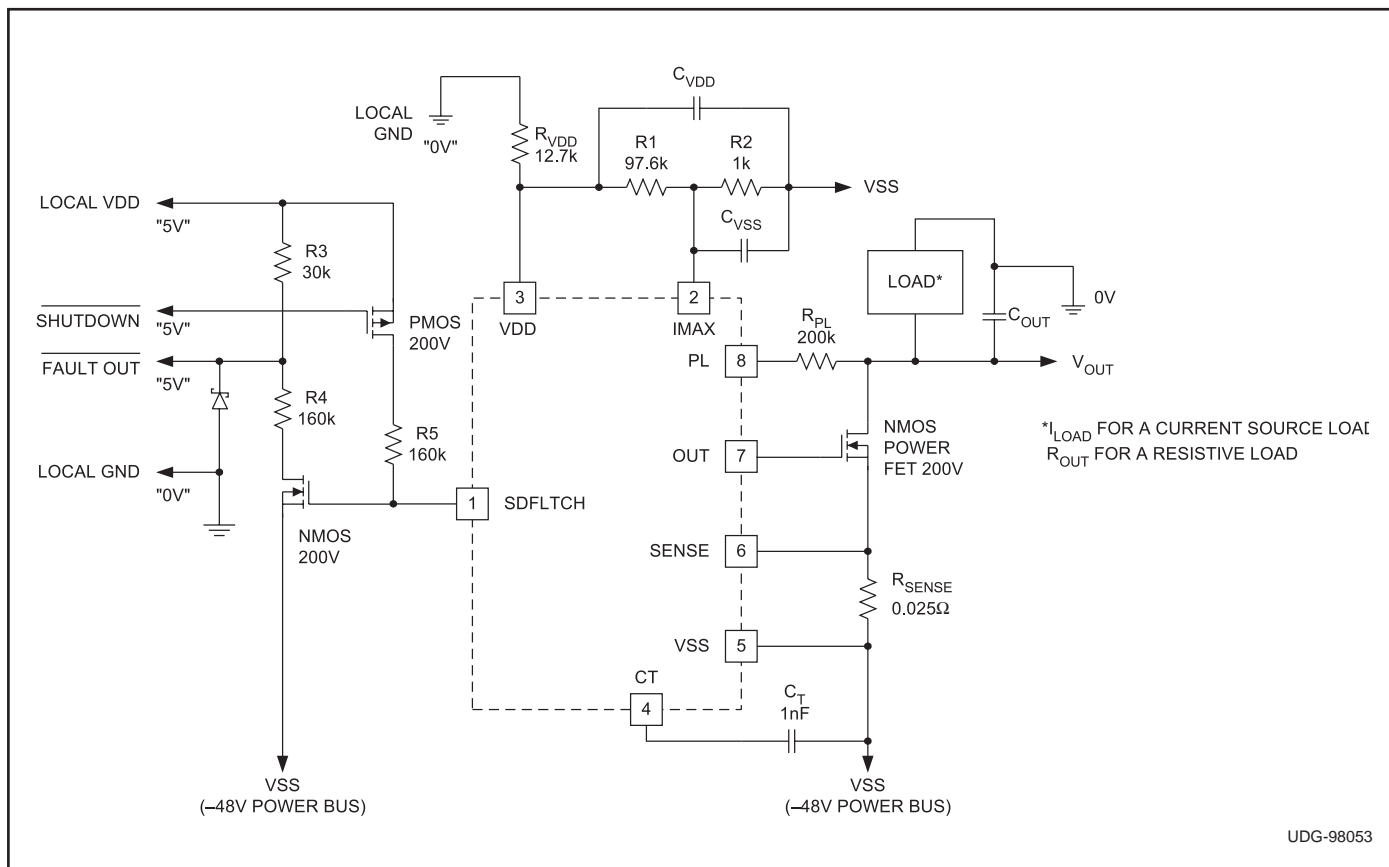

Figure 7. Typical Telecommunications Application
 (The "Negative Magnitude-Side" of the Supply is Switched in)

PACKAGING INFORMATION

Orderable Device	Status (1)	Package Type	Package Drawing	Pins	Package Qty	Eco Plan (2)	Lead finish/ Ball material (6)	MSL Peak Temp (3)	Op Temp (°C)	Device Marking (4/5)	Samples
UCC2921D	ACTIVE	SOIC	D	8	75	RoHS & Green	NIPDAU	Level-2-260C-1 YEAR	-40 to 85	UCC2921	Samples
UCC2921DG4	ACTIVE	SOIC	D	8	75	RoHS & Green	NIPDAU	Level-2-260C-1 YEAR	-40 to 85	UCC2921	Samples
UCC2921DTR	ACTIVE	SOIC	D	8	2500	RoHS & Green	NIPDAU	Level-2-260C-1 YEAR	-40 to 85	UCC2921	Samples
UCC3921D	ACTIVE	SOIC	D	8	75	RoHS & Green	NIPDAU	Level-1-260C-UNLIM	0 to 70	UCC3921	Samples
UCC3921DTR	ACTIVE	SOIC	D	8	2500	RoHS & Green	NIPDAU	Level-1-260C-UNLIM	0 to 70	UCC3921	Samples
UCC3921DTR/81143	ACTIVE	SOIC	D	8	2500	RoHS & Green	NIPDAU	Level-2-260C-1 YEAR		UCC3921	Samples

(1) The marketing status values are defined as follows:

ACTIVE: Product device recommended for new designs.

LIFEBUY: TI has announced that the device will be discontinued, and a lifetime-buy period is in effect.

NRND: Not recommended for new designs. Device is in production to support existing customers, but TI does not recommend using this part in a new design.

PREVIEW: Device has been announced but is not in production. Samples may or may not be available.

OBSOLETE: TI has discontinued the production of the device.

(2) **RoHS:** TI defines "RoHS" to mean semiconductor products that are compliant with the current EU RoHS requirements for all 10 RoHS substances, including the requirement that RoHS substance do not exceed 0.1% by weight in homogeneous materials. Where designed to be soldered at high temperatures, "RoHS" products are suitable for use in specified lead-free processes. TI may reference these types of products as "Pb-Free".

RoHS Exempt: TI defines "RoHS Exempt" to mean products that contain lead but are compliant with EU RoHS pursuant to a specific EU RoHS exemption.

Green: TI defines "Green" to mean the content of Chlorine (Cl) and Bromine (Br) based flame retardants meet JS709B low halogen requirements of <=1000ppm threshold. Antimony trioxide based flame retardants must also meet the <=1000ppm threshold requirement.

(3) MSL, Peak Temp. - The Moisture Sensitivity Level rating according to the JEDEC industry standard classifications, and peak solder temperature.

(4) There may be additional marking, which relates to the logo, the lot trace code information, or the environmental category on the device.

(5) Multiple Device Markings will be inside parentheses. Only one Device Marking contained in parentheses and separated by a "~" will appear on a device. If a line is indented then it is a continuation of the previous line and the two combined represent the entire Device Marking for that device.

(6) Lead finish/Ball material - Orderable Devices may have multiple material finish options. Finish options are separated by a vertical ruled line. Lead finish/Ball material values may wrap to two lines if the finish value exceeds the maximum column width.

Important Information and Disclaimer: The information provided on this page represents TI's knowledge and belief as of the date that it is provided. TI bases its knowledge and belief on information provided by third parties, and makes no representation or warranty as to the accuracy of such information. Efforts are underway to better integrate information from third parties. TI has taken and continues to take reasonable steps to provide representative and accurate information but may not have conducted destructive testing or chemical analysis on incoming materials and chemicals. TI and TI suppliers consider certain information to be proprietary, and thus CAS numbers and other limited information may not be available for release.

In no event shall TI's liability arising out of such information exceed the total purchase price of the TI part(s) at issue in this document sold by TI to Customer on an annual basis.

TAPE AND REEL INFORMATION



QUADRANT ASSIGNMENTS FOR PIN 1 ORIENTATION IN TAPE



*All dimensions are nominal

Device	Package Type	Package Drawing	Pins	SPQ	Reel Diameter (mm)	Reel Width W1 (mm)	A0 (mm)	B0 (mm)	K0 (mm)	P1 (mm)	W (mm)	Pin1 Quadrant
UCC2921DTR	SOIC	D	8	2500	330.0	12.4	6.4	5.2	2.1	8.0	12.0	Q1
UCC3921DTR	SOIC	D	8	2500	330.0	12.4	6.4	5.2	2.1	8.0	12.0	Q1
UCC3921DTR/81143	SOIC	D	8	2500	330.0	12.4	6.4	5.2	2.1	8.0	12.0	Q1

TAPE AND REEL BOX DIMENSIONS



*All dimensions are nominal

Device	Package Type	Package Drawing	Pins	SPQ	Length (mm)	Width (mm)	Height (mm)
UCC2921DTR	SOIC	D	8	2500	853.0	449.0	35.0
UCC3921DTR	SOIC	D	8	2500	853.0	449.0	35.0
UCC3921DTR/81143	SOIC	D	8	2500	367.0	367.0	35.0



D0008A

PACKAGE OUTLINE

SOIC - 1.75 mm max height

SMALL OUTLINE INTEGRATED CIRCUIT



NOTES:

1. Linear dimensions are in inches [millimeters]. Dimensions in parenthesis are for reference only. Controlling dimensions are in inches. Dimensioning and tolerancing per ASME Y14.5M.
2. This drawing is subject to change without notice.
3. This dimension does not include mold flash, protrusions, or gate burrs. Mold flash, protrusions, or gate burrs shall not exceed $.006$ [0.15] per side.
4. This dimension does not include interlead flash.
5. Reference JEDEC registration MS-012, variation AA.

EXAMPLE BOARD LAYOUT

D0008A

SOIC - 1.75 mm max height

SMALL OUTLINE INTEGRATED CIRCUIT



LAND PATTERN EXAMPLE
 EXPOSED METAL SHOWN
 SCALE:8X



SOLDER MASK DETAILS

4214825/C 02/2019

NOTES: (continued)

- 6. Publication IPC-7351 may have alternate designs.
- 7. Solder mask tolerances between and around signal pads can vary based on board fabrication site.

EXAMPLE STENCIL DESIGN

D0008A

SOIC - 1.75 mm max height

SMALL OUTLINE INTEGRATED CIRCUIT



SOLDER PASTE EXAMPLE
BASED ON .005 INCH [0.125 MM] THICK STENCIL
SCALE:8X

4214825/C 02/2019

NOTES: (continued)

8. Laser cutting apertures with trapezoidal walls and rounded corners may offer better paste release. IPC-7525 may have alternate design recommendations.
9. Board assembly site may have different recommendations for stencil design.

IMPORTANT NOTICE AND DISCLAIMER

TI PROVIDES TECHNICAL AND RELIABILITY DATA (INCLUDING DATASHEETS), DESIGN RESOURCES (INCLUDING REFERENCE DESIGNS), APPLICATION OR OTHER DESIGN ADVICE, WEB TOOLS, SAFETY INFORMATION, AND OTHER RESOURCES "AS IS" AND WITH ALL FAULTS, AND DISCLAIMS ALL WARRANTIES, EXPRESS AND IMPLIED, INCLUDING WITHOUT LIMITATION ANY IMPLIED WARRANTIES OF MERCHANTABILITY, FITNESS FOR A PARTICULAR PURPOSE OR NON-INFRINGEMENT OF THIRD PARTY INTELLECTUAL PROPERTY RIGHTS.

These resources are intended for skilled developers designing with TI products. You are solely responsible for (1) selecting the appropriate TI products for your application, (2) designing, validating and testing your application, and (3) ensuring your application meets applicable standards, and any other safety, security, or other requirements. These resources are subject to change without notice. TI grants you permission to use these resources only for development of an application that uses the TI products described in the resource. Other reproduction and display of these resources is prohibited. No license is granted to any other TI intellectual property right or to any third party intellectual property right. TI disclaims responsibility for, and you will fully indemnify TI and its representatives against, any claims, damages, costs, losses, and liabilities arising out of your use of these resources.

TI's products are provided subject to TI's Terms of Sale (<https://www.ti.com/legal/termsofsale.html>) or other applicable terms available either on [ti.com](https://www.ti.com) or provided in conjunction with such TI products. TI's provision of these resources does not expand or otherwise alter TI's applicable warranties or warranty disclaimers for TI products.

Mailing Address: Texas Instruments, Post Office Box 655303, Dallas, Texas 75265
Copyright © 2021, Texas Instruments Incorporated